



Altos caudales



CAMPO DE PRESTACIONES

- Caudal hasta **2200 l/min** (132 m³/h)
- Altura manométrica hasta **24.5 m**

LIMITES DE UTILIZO

- Altura de aspiración manométrica hasta **7 m**
- Temperatura del líquido de **-10 °C** hasta **+90 °C**
- Temperatura ambiente hasta **+40 °C**
- Presión máx. en el cuerpo de la bomba:
 - **6 bar** para HF 4
 - **10 bar** para HF 6-8-20-30
- Funcionamiento continuo **S1**

EJECUCION Y NORMAS DE SEGURIDAD

EN 60034-1
IEC 60034-1
CEI 2-3



CERTIFICACIONES



UTILIZOS E INSTALACIONES

Son recomendadas para utilizarse en el sector civil y agrícola. Sus elevados rendimientos y la posibilidad de un funcionamiento continuo permiten el uso de estas electrobombas para la irrigación por gravedad, por aspersión, para el bombeo del agua de lagos, ríos, pozos y para muchas otras aplicaciones industriales caracterizadas por la necesidad de tener caudales considerables con alturas medio bajas.

La instalación se debe realizar en lugares cerrados o protegidos de la intemperie.

EJECUCION BAJO PEDIDO

- Sello mecánico especial
- Otros voltajes o frecuencia 60 Hz

GARANTIA

2 años según nuestras condiciones generales de venta

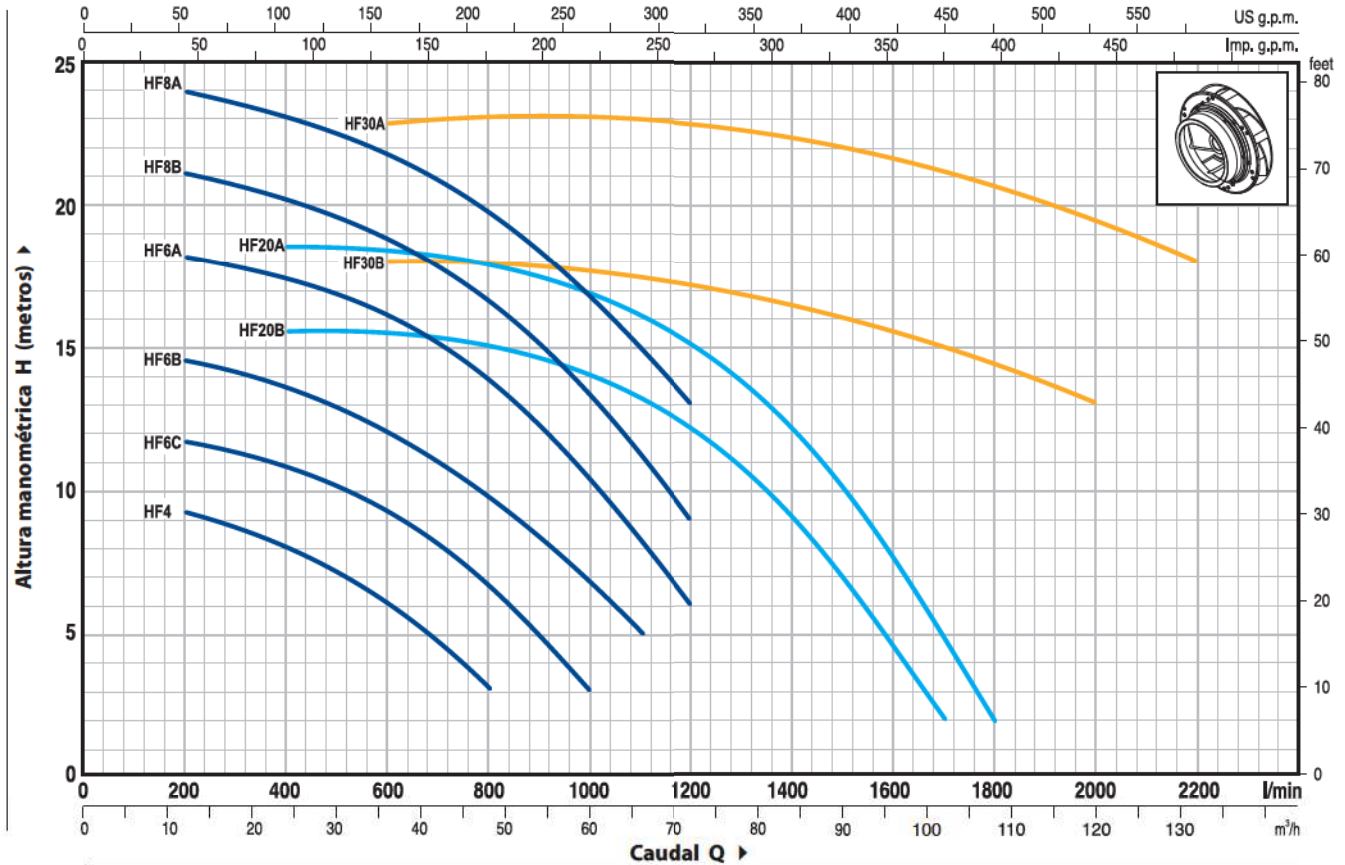
CURVAS Y DATOS DE PRESTACIONES
50 Hz n=2900 1/min HS= 0 m

MODELO		POTENCIA		Q	H metros																		
Monofásica	Trifásica	kW	HP		m³/h	0	12	18	24	30	36	42	48	54	60	66	72	84	96	102	108	120	132
				l/min	0	200	300	400	500	600	700	800	900	1000	1100	1200	1400	1600	1700	1800	2000	2200	
HFm 4	HF 4	0.75	1		10	9.3	8.7	8	7	6	4.7	3											
HFm 6C	HF 6C	1.1	1.5		11.9	11.7	11.3	10.7	10.2	9.2	8	6.7	5	3									
HFm 6B	HF 6B	1.5	2		14.7	14.5	14	13.5	12.8	12	11	9.7	8.2	6.7	5								
-	HF 6A	2.2	3		18.5	18.1	17.8	17.2	16.8	16	15	13.8	12.2	10.5	8.3	6							
-	HF 8B	3	4		21.5	21	20.7	20	19.5	18.8	17.8	16.5	15	13.5	11.2	9							
-	HF 8A	4	5.5		24.5	24	23.5	23	22.5	21.8	20.8	19.5	18.3	16.8	15	13							
-	HF 20B	3	4		16	-	-	15.5	15.4	15.3	15.2	15	14.5	14	13	12	9	4.8	2				
-	HF 20A	4	5.5		19	-	-	18.5	18.4	18.3	18.2	18	17.5	17	16.2	15.2	12	7.8	5	2			
-	HF 30B	5.5	7.5		18	-	-	-	-	18	18	18	18	18	17.5	17	16.5	15.5	15	14.5	13		
-	HF 30A	7.5	10		23	-	-	-	-	23	23	23	23	23	23	22.5	22.5	22.5	22	21.5	21	19.5	18

Q = Caudal H = Altura manométrica total HS = Altura de aspiración

Tolerancia de las curvas de prestación según EN ISO9906 App. A.

POS.	COMPONENTE	CARACTERISTICAS CONSTRUCTIVAS					
1	CUERPO BOMBA	Hierro fundido, con bocas roscadas ISO 228/1					
2	TAPA	Hierro fundido (en acero inoxidable AISI 304 para HF 4)					
3	RODETE	Latón para HF 4, HF 6, HF 8, HF 20 Hierro fundido para HF 30					
4	EJE MOTOR	Acero inoxidable EN 10088-3 - 1.4104					
5	SELLO MECANICO	Electrobomba	Sello	Eje	Materiales		
		<i>Modelo</i>	<i>Modelo</i>	<i>Diámetro</i>	<i>Anillo fijo</i>	<i>Anillo móvil</i>	<i>Elastómero</i>
		HF 4	AR-14	Ø 14 mm	Cerámica	Grafito	NBR
		HF 6	FN-18	Ø 18 mm	Grafito	Cerámica	NBR
		HF 8-20	FN-20	Ø 20 mm	Grafito	Cerámica	NBR
		HF 30	FN-24	Ø 24 mm	Grafito	Cerámica	NBR
6	RODAMIENTOS	Electrobomba	Modelo				
		HF 4	6203 ZZ / 6203 ZZ				
		HF 6	6304 ZZ / 6204 ZZ				
		HF 8B-20B	6206 ZZ - C3 / 6205 ZZ				
		HF 8A-20A	6306 ZZ - C3 / 6206 ZZ - C3				
		HF 30	6307 ZZ - C3 / 6206 ZZ - C3				
7	CONDENSADOR	Electrobomba	Capacidad				
		<i>Monofásica</i>	<i>(230 V o 240 V)</i>	<i>(110 V)</i>			
		HFm 4	20 µF 450 VL	60 µF 300 VL			
		HFm 6C	31.5 µF 450 VL	60 µF 250 VL			
		HFm 6B	45 µF 450 VL	80 µF 250 VL			
8	MOTOR ELECTRICO	HFm: monofásica 230 V - 50 Hz con protección térmica incorporada en el bobinado. HF: trifásica 230/400 V - 50 Hz hasta 4 kW, 400/690 V - 50 Hz de 5.5 a 7.5 kW ⇒ Las bombas con motores trifásicos son de alto rendimiento en clase IE2 (IEC 60034-30) – Aislamiento: clase F. – Protección: IP 44.					

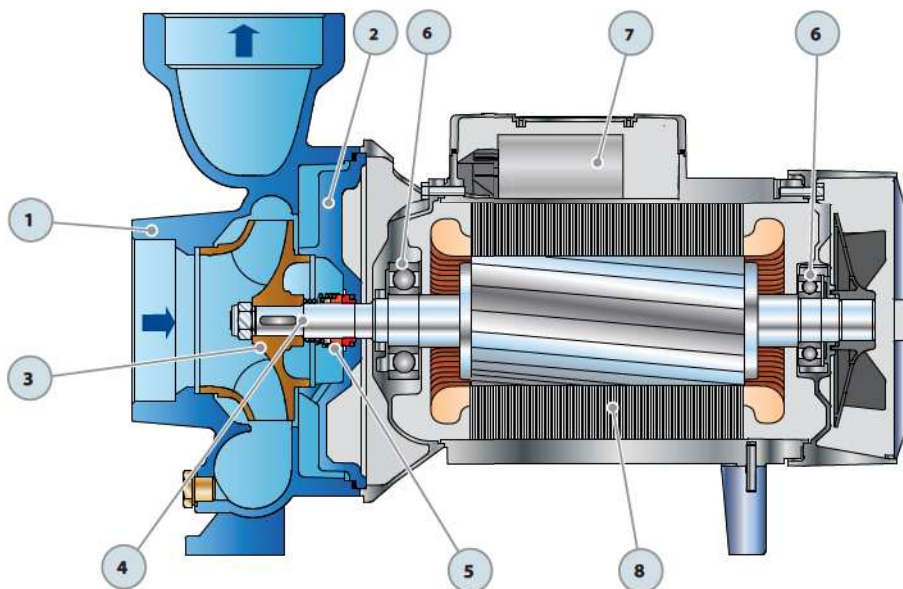

DIMENSIONES Y PESOS

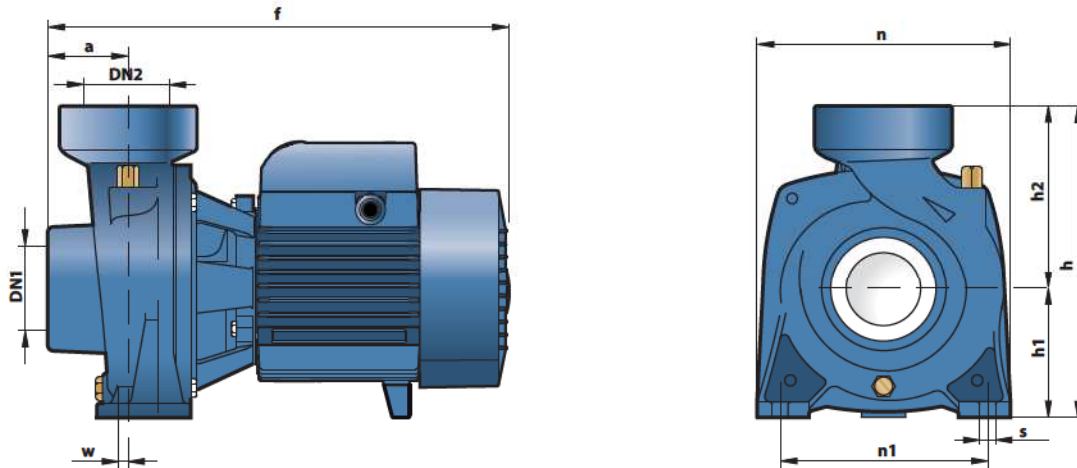

MODELO		BOCAS		DIMENSIONES mm									kg	
Monofásica	Trifásica	DN1	DN2	a	f	h	h1	h2	n	n1	w	s	1~	3~
HFm 4	HF 4	2½"	2½"	55	323	240	97	143	198	155	0	10	14.5	13.2
HFm 6C	HF 6C	3"	3"	68	411	312	120	192	240	190	6	12	25.5	24.2
HFm 6B	HF 6B												26.5	25.5
-	HF 6A	4"	4"	80	435	465	132	180	245	190	30	14	-	26.7
-	HF 8B												-	35.0
-	HF 8A												-	40.0
-	HF 20B												-	35.0
-	HF 20A	-	40.0											
-	HF 30B	-	60.9											
-	HF 30A	-	65.2											

CONSUMO EN AMPERIOS

MODELO	TENSION (monofásica)		
	230 V	240 V	110 V
HFm 4	5.9 A	5.3 A	11.8 A
HFm 6C	8.8 A	8.0 A	17.6 A
HFm 6B	10.8 A	9.8 A	21.6 A

MODELO	TENSION (trifásica)					
	230 V	400 V	690 V	240 V	415 V	720 V
HF 4	4.3 A	2.5 A	1.4 A	4.0 A	2.3 A	1.3 A
HF 6C	6.2 A	3.6 A	2.1 A	6.0 A	3.5 A	2.0 A
HF 6B	8.0 A	4.6 A	2.7 A	7.4 A	4.3 A	2.5 A
HF 6A	9.0 A	5.2 A	3.0 A	8.3 A	4.8 A	2.8 A
HF 8B	11.8 A	6.8 A	3.9 A	12.1 A	7.0 A	4.0 A
HF 8A	15.8 A	9.1 A	5.3 A	15.2 A	8.8 A	5.1 A
HF 20B	13.0 A	7.5 A	4.3 A	13.4 A	7.7 A	4.4 A
HF 20A	15.2 A	8.8 A	5.1 A	15.3 A	8.8 A	5.1 A
HF 30B	21.3 A	12.3 A	7.1 A	20.4 A	11.8 A	6.8 A
HF 30A	28.6 A	16.5 A	9.5 A	27.5 A	15.9 A	9.2 A

PALETIZADO

MODELO		PARA GRUPAJE				PARA CONTAINER			
		n° bombas	H (mm)	1~	3~	n° bombas	H (mm)	1~	3~
Monofásica	Trifásica								
HFm 4	HF 4	60	1540	890	830	84	2100	1240	1150
HFm 6C	HF 6C	36	1480	940	890	54	2150	1400	1330
HFm 6B	HF 6B	36	1480	970	940	54	2150	1450	1400
-	HF 6A	36	1480	-	980	54	2150	-	1460
-	HF 8B	18	1430	-	650	24	1860	-	860
-	HF 8A	18	1430	-	740	24	1860	-	980
-	HF 20B	18	1430	-	650	24	1860	-	860
-	HF 20A	18	1430	-	740	24	1860	-	980
-	HF 30B	12	1570	-	750	16	2040	-	990
-	HF 30A	12	1570	-	800	16	2040	-	1060

