



COMPANY
WITH QUALITY SYSTEM
CERTIFIED BY DNV
= ISO 9001/2000 =

Water technology at your service



serie **blue**®

DESIGN BY

pininfarina

50 Hz



ESPAÑOL

2 AÑOS DE GARANTÍA

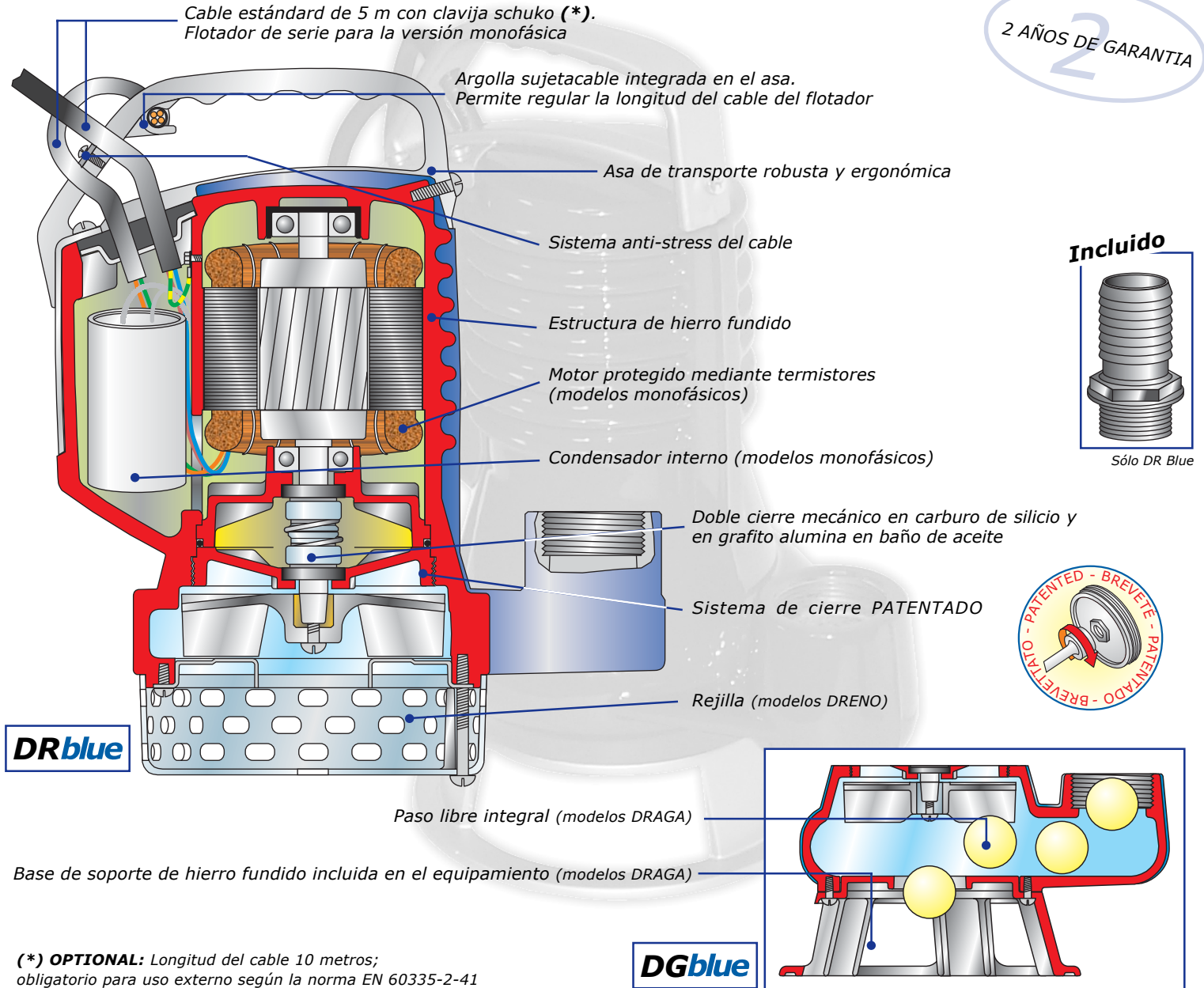

DRblue

DGblue

(*) **OPTIONAL:** Longitud del cable 10 metros; obligatorio para uso externo según la norma EN 60335-2-41

Pininfarina: un parter excepcional

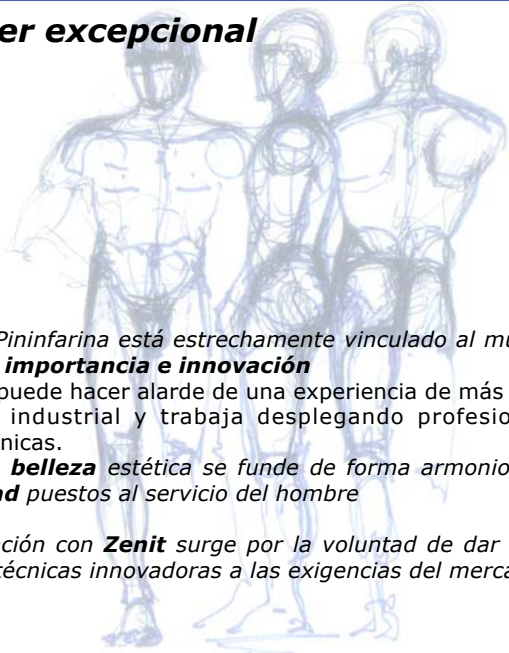

Concept car Enjoy 2003

El nombre Pininfarina está estrechamente vinculado al mundo de los coches deportivos y es expresión de **elegancia, importancia e innovación**. Pininfarina puede hacer alarde de una experiencia de más de setenta años en el sector de la proyectación y del diseño industrial y trabaja desplegando profesionalidad y competencia en numerosas áreas mercadotécnicas. La **idea de belleza** estética se funde de forma armoniosa con los conceptos de **seguridad, confort y modernidad** puestos al servicio del hombre. La colaboración con **Zenit** surge por la voluntad de dar una nueva imagen al producto y responder con soluciones técnicas innovadoras a las exigencias del mercado.

DR blue

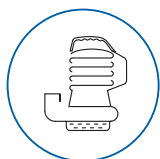

DR blue		Impulsor multicanal abierto						
Modelo	Fases	Potencia		Intensidad	Rev./min	Caudal	Agujeros rejilla	
		kW	HP	(A)		(Ø mm)	(mm)	
① DR blue 40 M	1	0.3	0.4	2.3	2900	1¼"	12 x 7	
② DR blue 50 M	1	0.37	0.5	2.8	2900	1¼"	12 x 7	
③ DR blue 75 M	1	0.55	0.75	4.1	2900	1¼"	12 x 7	
③ DR blue 75 T	3	0.55	0.75	1.45	2900	1¼"	12 x 7	
④ DR blue 100 M	1	0.74	1.0	5.6	2900	1¼"	12 x 7	
④ DR blue 100 T	3	0.74	1.0	2.15	2900	1¼"	12 x 7	

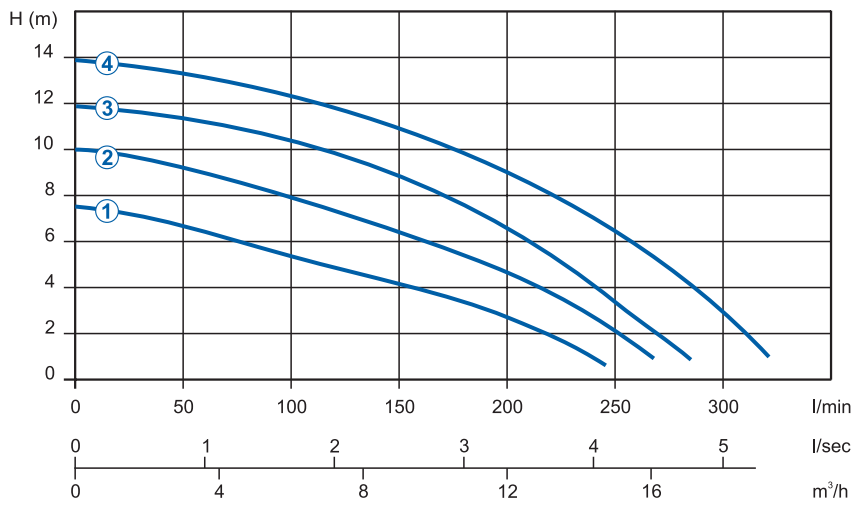

DG blue



DG blue		Impulsor desplazado del tipo vortex						
Modelo	Fases	Potencia		Intensidad	Rev./min	Caudal	Paso libre	
		kW	HP	(A)		(Ø mm)	(mm)	
⑤ DG blue 40 M	1	0.3	0.4	2.3	2900	1½"	35	
⑥ DG blue 50 M	1	0.37	0.5	2.8	2900	1½"	35	
⑦ DG blue 75 M	1	0.55	0.75	4.1	2900	1½"	35	
⑦ DG blue 75 T	3	0.55	0.75	1.45	2900	1½"	35	
⑧ DG blue 100 M	1	0.74	1.0	5.6	2900	1½"	35	
⑧ DG blue 100 T	3	0.74	1.0	2.15	2900	1½"	35	

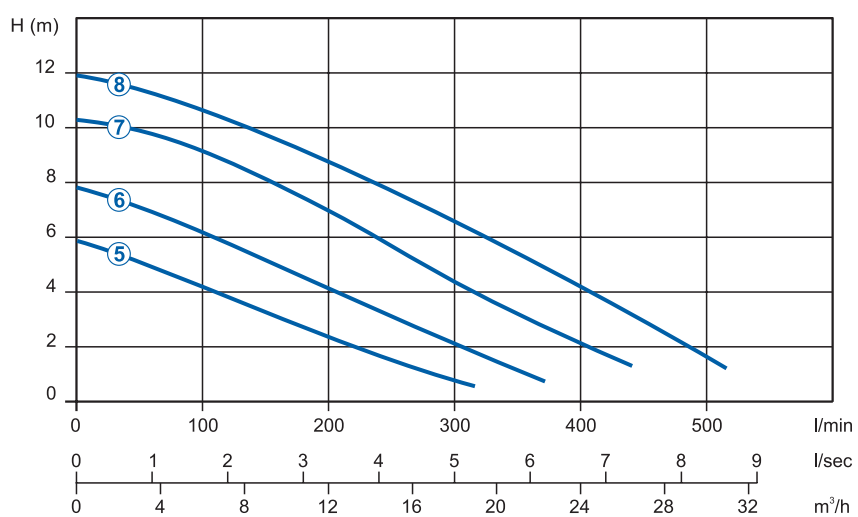

DR blue

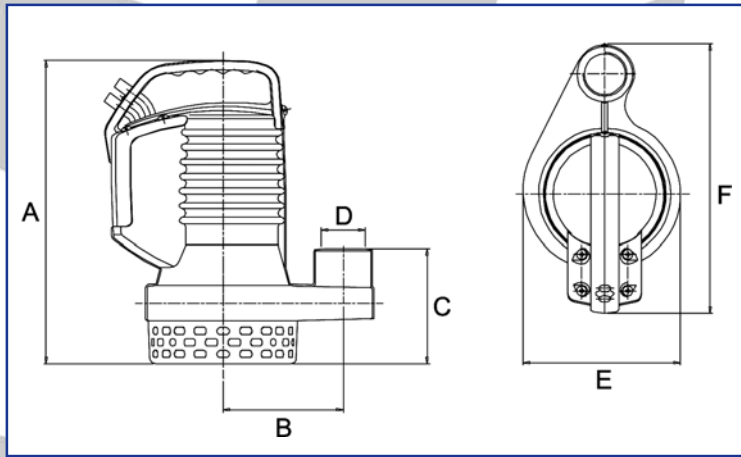

DG blue

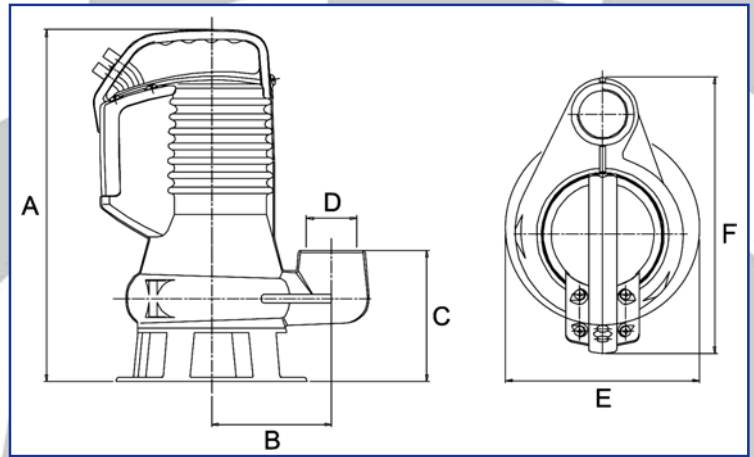

- DR blue -

Modelo	A	B	C	D	E	F	Kg
DR blue 40	289	114	110	1¼"	150	257	11.5
DR blue 50	289	114	110	1¼"	150	257	12.0
DR blue 75	317	114	110	1¼"	150	257	13.5
DR blue 100	317	114	110	1¼"	150	257	14.0

- DG blue -

Modelo	A	B	C	D	E	F	Kg
DG blue 40	335	114	125	1½"	182	263	12.5
DG blue 50	335	114	125	1½"	182	263	13.0
DG blue 75	363	114	125	1½"	182	263	15.0
DG blue 100	363	114	125	1½"	182	263	15.5

Instalaciones

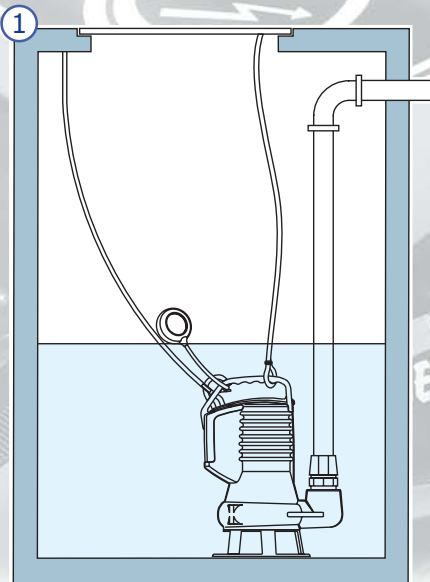

Instalación mediante tubo y relativo racor de polietileno

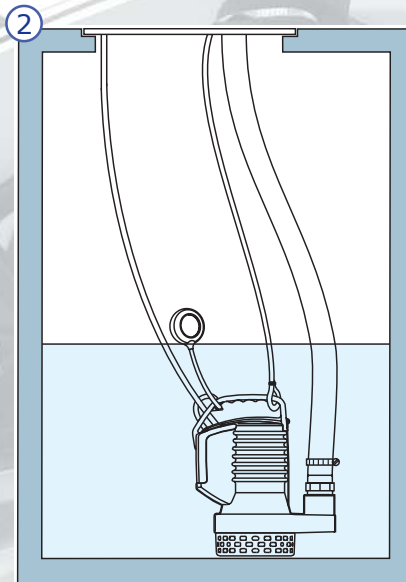

Instalación mediante racor boquilla y manguera

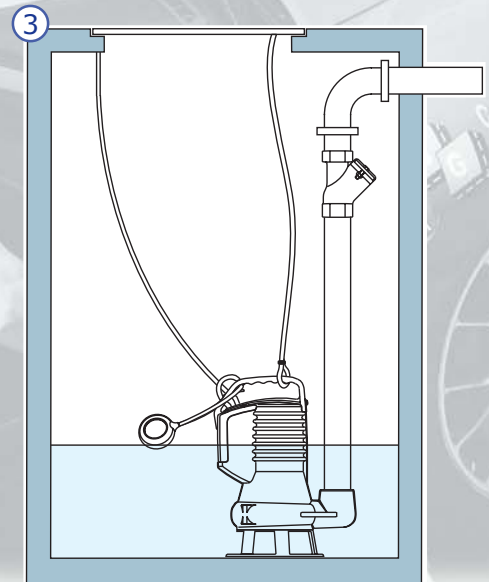

Instalación fija mediante tubo metálico roscado



via dell'Industria, 15 I - 41018 S.Cesario sul Panaro (MO) - Italy
 Tel. +39.059.950.611 fax +39.059.950.690
 Customer service: Tel. +39.059.950.612 Fax +39.059.950.692
 www.zenit.net info@zenit.net