

ELECTRO-MECHANICAL UNIT	Rated delivered power:	0,55 kW	Motor poles/revolutions:	2900 1/min - 2Poles
	Rated absorbed power:	0,86 kW	Motor phases:	M - Single-phase
	Rated absorbed current:	3,8 A	Service:	S1 submersible or w/sleeve
	Starting current:	Not available	Motor protection:	IP 68
	Starting torque:	Not available	Insulation class (ICL):	F
	Rated Cos Ø:	0,98	Max. Starts per hour:	20
	Rated motor performance:	64%	Standard cable type:	5 mt-H07RN-F 3G1
	Detailed description of series:	Submersible pumps consisting of a EN-GJL-250 cast iron electromechanical unit intended for submersible operation with 1 mechanical seal and 1 lip seal conventionally installed. Explosion-proof version not available.*		
	Standard mechanical seals	1 mechanical graphite alumina (NBR) seal and 1 lip seal		
	Lifting:	With handle on motor cover		
	Ball bearings:	Upper and lower permanently lubricated ball bearings		
	Winding type:	Induction motor with dry winding and automatic overload protection		
Impregnation type:	Doubly impregnated humidity-resistant winding			
Direction of rotation:	Clockwise seen from top of electric pump			
Data provided above refers to hydraulic tests carried out at: 230 Volt 50 Hz				

MATERIALS	Mechanical unit:	EN-GJL-250 cast iron	Hyd. Unit, impeller:	EN-GJL-250 cast iron
	Shaft:	X6Cr13 (AISI416) steel	Bolts and Screws:	INOX A2 steel
	Seals (O-Ring):	NBR-SBR rubber	Grinder cutter:	Not applicable
	**Cooling jacket:	Not applicable	Painting:	Ecological epoxy vinyl
** Cooling jacket supplied upon request in series specified				

LIMITS ON USE REFERENCE STANDARDS	Max. operating temp.:	40 °C	Max. sub. depth:	20 m
	Liquid PH:	6 to 10	Liquid density:	1 kg/dm ³
	Viscosity of liquid:	1 mm ² /s	Max. acoustic press.:	< 70 dB dB
	Reference standards:			
	<ul style="list-style-type: none"> • EN 292-1; EN 292-2; CEI EN 60529; ISO 9906; CEI EN 60034-1. • CEI EN 60204; UNI ISO 6009; UNI EN 1561-1563; UNI EN 10098. • Low voltage directive 73/23/CEE. • Procedures specified by Zenit S.p.a. Quality System, UNI EN ISO 9001 (ISO 9001) certified, DNV n. SQ 0660-IT certified. • Machines directive 89/392/CEE and successive amendments thereto (directives 91/368/CEE, 93/68/CEE), electromagnetic compatibility directive 89/336/CEE 			

SYMBOLS	Product complying with European standards in force	Company Quality System complying with UNI ISO norm
---------	--	--

VARIANTS AVAILABLE	Electrical accessories	
	TC	Thermistor and capacitor
	TCG	Thermistor, capacitor and float
	Set of mechanical seals	
	ALM	1 mechanical graphite alumina (NBR) seal and 1 lip seal
	SICM	1 mechanical silicon carbide (Viton) seal and 1 lip seal
	Cooling system / mechanical seal flushing versions*	
N	No sleeve and/or seal flushing	

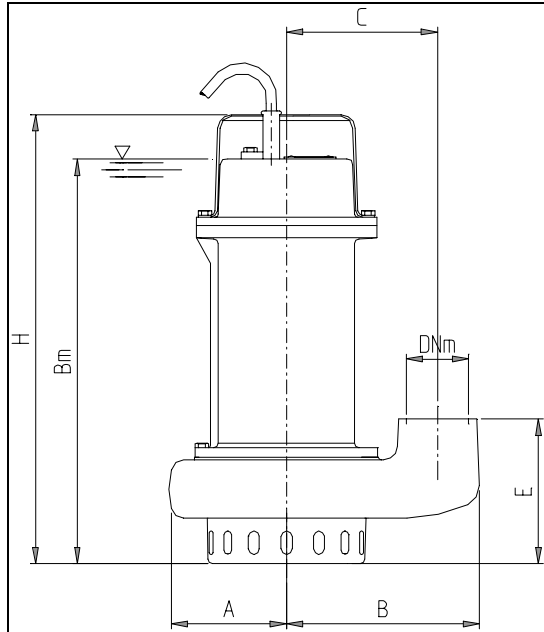

A	B	Bm	C	DNm	DNm4	E
78	132	290	103	1 1/4	2	110
EB	ED	EE	EF	EG	EP	EQ
240	1 1/4-2	87	98.5	278	70.5	75.5
ER	H	H4	L4	M4		
54	335	18	165	125		

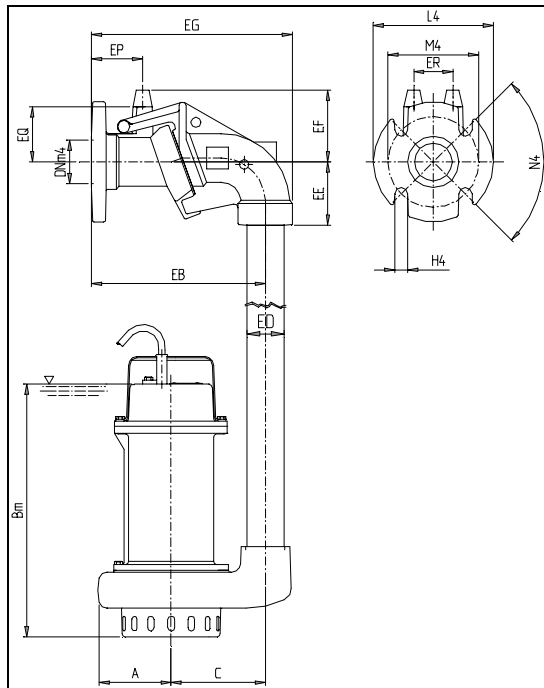

• These drawings do not represent actual product appearance. Refer to the outline on the previous page.

Dimensions 'mm' except than: DNm-inches DNm4-inches ED-inches	Mass:	13 Kg	Possible installations:	I1-I2-I3
---	-------	-------	-------------------------	----------

*For more information see the descriptive sections