

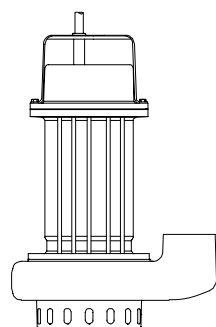
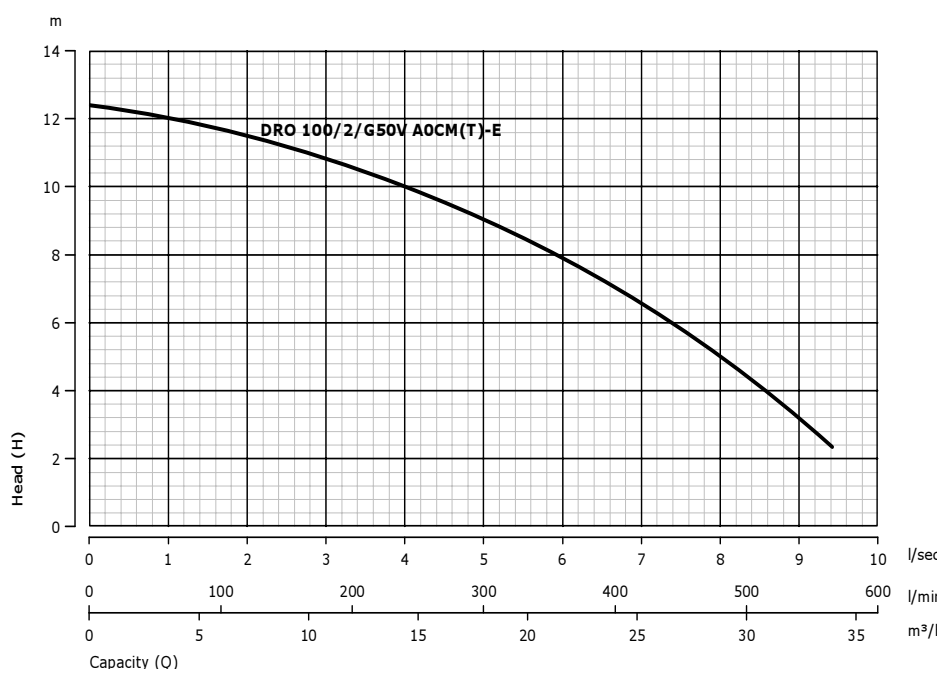

<h1>DRO 100/2/G50V A0CM-E</h1>	Hydraulic model: "A"	
 <p style="text-align: center;">% = Hydraulic Performance - P2 = Power Delivered</p>	ACTUAL OUTLINE	<p>Hydraulic type:</p> <p>Multi-channel open high performance impeller*</p> <p>Power/poles:</p> <p>0,88 kW - 2 Poles</p> <p>Outlet type:</p> <p>2" vertical gas threaded opening</p> <p>Explosion-proof:</p> <p>Pump in NOT ex-proof version</p> <p>Free passage of solid bodies:</p> <p>Strainer holes (10x20 mm)</p>

ELECTRO-MECHANICAL UNIT	Rated delivered power:	0,88 kW	Motor poles/revolutions:	2900 1/min - 2Poles	
	Rated absorbed power:	1,38 kW	Motor phases:	M - Single-phase	
	Rated absorbed current:	6,5 A	Service:	S1 submersible or w/sleeve	
	Starting current:	Not available	Motor protection:	IP 68	
	Starting torque:	Not available	Insulation class (ICL):	F	
	Rated Cos Ø:	0,92	Max. Starts per hour:	20	
	Rated motor performance:	64%	Standard cable type:	5 mt-H07RN-F 4G1	
	Detailed description of series:	Submersible pumps consisting of a EN-GJL-250 cast iron electromechanical unit intended for submersible operation, equipped with 2 conventionally installed mechanical seals. Oil filled motor. Separate hydraulic unit. Explosion-proof version not available.*			
	Standard mechanical seals	1 mechanical silicon carbide (Viton) seal and 1 mechanical graphite alumina (NBR) seal			
	Lifting:	With handle on motor cover			
Ball bearings:	Upper permanently lubricated ball bearing, lower oil-immersed ball bearing				
Winding type:	Induction motor with oil-filled winding and automatic overload protection				
Impregnation type:	Doubly impregnated humidity-resistant winding				
Direction of rotation:	Clockwise seen from top of electric pump				
Data provided above refers to hydraulic tests carried out at: 230 Volt 50 Hz					

MATERIALS	Mechanical unit:	EN-GJL-250 cast iron	Hyd. Unit, impeller:	EN-GJL-250 cast iron
	Shaft:	X6Cr13 (AISI416) steel	Bolts and Screws:	INOX A2 steel
	Seals (O-Ring):	NBR-SBR rubber	Grinder cutter:	Not applicable
	**Cooling jacket:	Not applicable	Painting:	Ecological epoxy vinyl
** Cooling jacket supplied upon request in series specified				

LIMITS ON USE REFERENCE STANDARDS	Max. operating temp.:	40 °C	Max. sub. depth:	20 m
	Liquid PH:	6 to 10	Liquid density:	1 kg/dm ³
	Viscosity of liquid:	1 mm ² /s	Max. acoustic press.:	< 70 dB dB
	Reference standards:			
	<ul style="list-style-type: none"> • EN 292-1; EN 292-2; CEI EN 60529; ISO 9906; CEI EN 60034-1. • CEI EN 60204; UNI ISO 6009; UNI EN 1561-1563; UNI EN 10098. • Low voltage directive 73/23/CEE. • Procedures specified by Zenit S.p.a. Quality System, UNI EN ISO 9001 (ISO 9001) certified, DNV n. SQ 0660-IT certified. • Machines directive 89/392/CEE and successive amendments thereto (directives 91/368/CEE, 93/68/CEE), electromagnetic compatibility directive 89/336/CEE 			

SYMBOLS	 <p>Product complying with European standards in force</p>	<p>Company Quality System complying with UNI ISO norm</p>
----------------	---	---

VARIANTS AVAILABLE	Electrical accessories	
	<i>T</i>	Thermistor
	<i>TCST</i>	Thermistor, capacitor, starter box and overload protection
	<i>TCSGT</i>	Thermistor, capacitor, starter box, float and overload protection
	<i>TCSGLT</i>	Thermistor, capacitor, starter box, 0.5 m float and overload protection
	Set of mechanical seals	
	<i>SICAL</i>	1 mechanical silicon carbide (Viton) seal and 1 mechanical graphite alumina (NBR) seal
<i>2SIC</i>	2 mechanical silicon carbide (Viton) seals	
Cooling system / mechanical seal flushing versions*		
<i>N</i>	No sleeve and/or seal flushing	

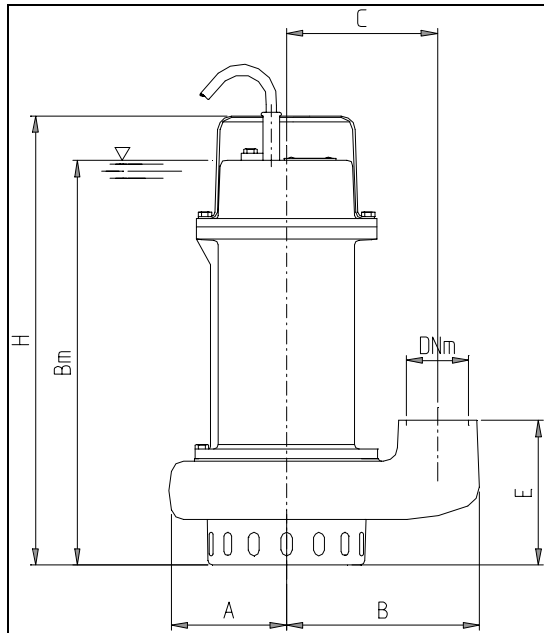

A	B	Bm	C	DNm	DNm4	E
100	166	347	130	2	2	124
EB	ED	EE	EF	EG	EP	EQ
240	2	87	98.5	278	70.5	75.5
ER	H	H4	L4	M4		
54	385	18	165	125		

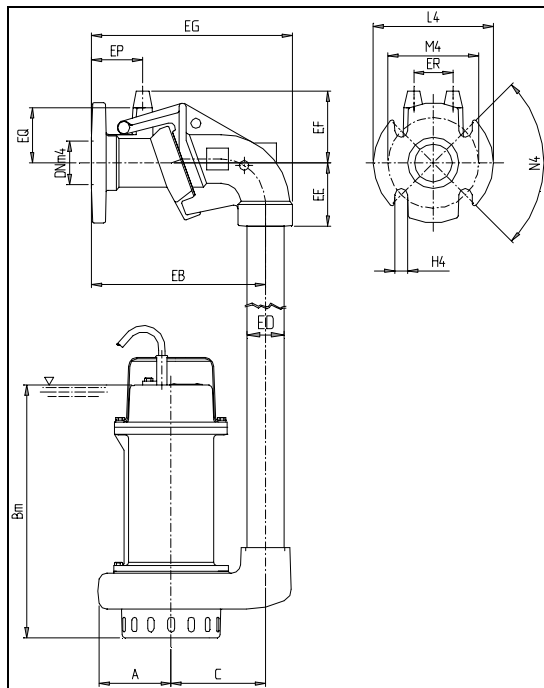

• These drawings do not represent actual product appearance. Refer to the outline on the previous page.

Dimensions 'mm' except than: DNm-inches DNm4-inches ED-inches	Mass: 19,5 Kg	Possible installations:	I1-I2-I3
---	----------------------	--------------------------------	----------

*For more information see the descriptive sections