

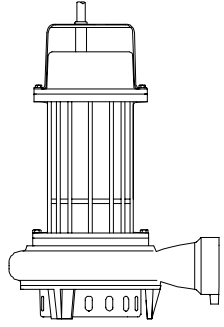
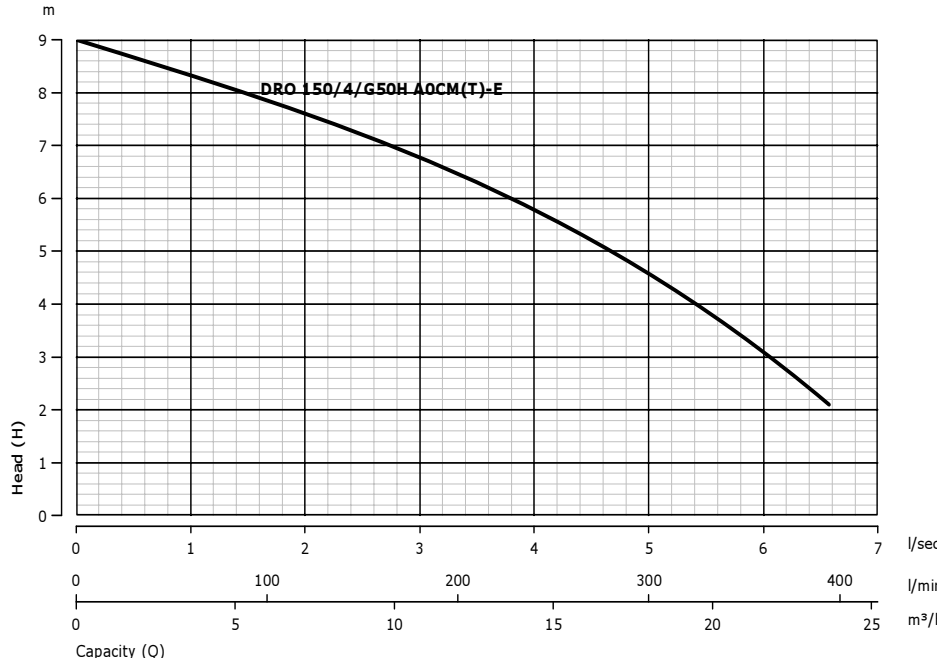

<h1>DRO 150/4/G50H A0CT-E</h1>	Hydraulic model: <b>"A"</b>	
 <p style="text-align: center;">% = Hydraulic Performance - P2 = Power Delivered</p>	<b>ACTUAL OUTLINE</b>	<p><b>Hydraulic type:</b></p> <p>Multi-channel open high performance impeller*</p> <p><b>Power/poles:</b></p> <p>0,9 kW - 4 Poles</p> <p><b>Outlet type:</b></p> <p>2" horizontal gas threaded opening</p> <p><b>Explosion-proof:</b></p> <p>Pump in NOT ex-proof version</p> <p><b>Free passage of solid bodies:</b></p> <p>Strainer holes ( 10x20 mm)</p>

<b>ELECTRO-MECHANICAL UNIT</b>	Rated delivered power:	0,9 kW	Motor poles/revolutions:	1450 1/min - 4Poles	
	Rated absorbed power:	1,22 kW	Motor phases:	T - Three-phase	
	Rated absorbed current:	2,23 A	Service:	S1 submersible or w/sleeve	
	Starting current:	Not available	Motor protection:	IP 68	
	Starting torque:	Not available	Insulation class (ICL):	F	
	Rated Cos Ø:	0,79	Max. Starts per hour:	20	
	Rated motor performance:	74%	Standard cable type:	5 mt-H07RN-F 4G1	
	Detailed description of series:	Submersible pumps consisting of a EN-GJL-250 cast iron electromechanical unit intended for submersible operation, equipped with 2 conventionally installed mechanical seals. Oil filled motor. Separate hydraulic unit. Explosion-proof version not available.*			
	Standard mechanical seals	1 mechanical silicon carbide (Viton) seal and 1 mechanical graphite alumina (NBR) seal			
	Lifting:	With handle on motor cover			
Ball bearings:	Upper permanently lubricated ball bearing, lower oil-immersed ball bearing				
Winding type:	Induction motor with oil-filled winding				
Impregnation type:	Doubly impregnated humidity-resistant winding				
Direction of rotation:	Clockwise seen from top of electric pump				
Data provided above refers to hydraulic tests carried out at: 400 Volt 50 Hz					

<b>MATERIALS</b>	<b>Mechanical unit:</b>	EN-GJL-250 cast iron	<b>Hyd. Unit, impeller:</b>	EN-GJL-250 cast iron
	<b>Shaft:</b>	X6Cr13 (AISI416) steel	<b>Bolts and Screws:</b>	INOX A2 steel
	<b>Seals (O-Ring):</b>	NBR-SBR rubber	<b>Grinder cutter:</b>	Not applicable
	<b>**Cooling jacket:</b>	Not applicable	<b>Painting:</b>	Ecological epoxy vinyl
** Cooling jacket supplied upon request in series specified				

<b>LIMITS ON USE REFERENCE STANDARDS</b>	<b>Max. operating temp.:</b>	40 °C	<b>Max. sub. depth:</b>	20 m
	<b>Liquid PH:</b>	6 to 10	<b>Liquid density:</b>	1 kg/dm³
	<b>Viscosity of liquid:</b>	1 mm²/s	<b>Max. acoustic press.:</b>	< 70 dB dB
	<b>Reference standards:</b>			
	<ul style="list-style-type: none"> <li>• EN 292-1; EN 292-2; CEI EN 60529; ISO 9906; CEI EN 60034-1.</li> <li>• CEI EN 60204; UNI ISO 6009; UNI EN 1561-1563; UNI EN 10098.</li> <li>• Low voltage directive 73/23/CEE.</li> <li>• Procedures specified by Zenit S.p.a. Quality System, UNI EN ISO 9001 (ISO 9001) certified, DNV n. SQ 0660-IT certified.</li> <li>• Machines directive 89/392/CEE and successive amendments thereto (directives 91/368/CEE, 93/68/CEE), electromagnetic compatibility directive 89/336/CEE</li> </ul>			

<b>SYMBOLS</b>	 <p>Product complying with European standards in force</p>	<p>Company Quality System complying with UNI ISO norm</p>
----------------	---	---

<b>VARIANTS AVAILABLE</b>	<b>Electrical accessories</b>	
	NAE	No electrical accessories installed
	T	Thermistor
	<b>Set of mechanical seals</b>	
	SICAL	1 mechanical silicon carbide (Viton) seal and 1 mechanical graphite alumina (NBR) seal
	2SIC	2 mechanical silicon carbide (Viton) seals
<b>Cooling system / mechanical seal flushing versions*</b>		
N	No sleeve and/or seal flushing	

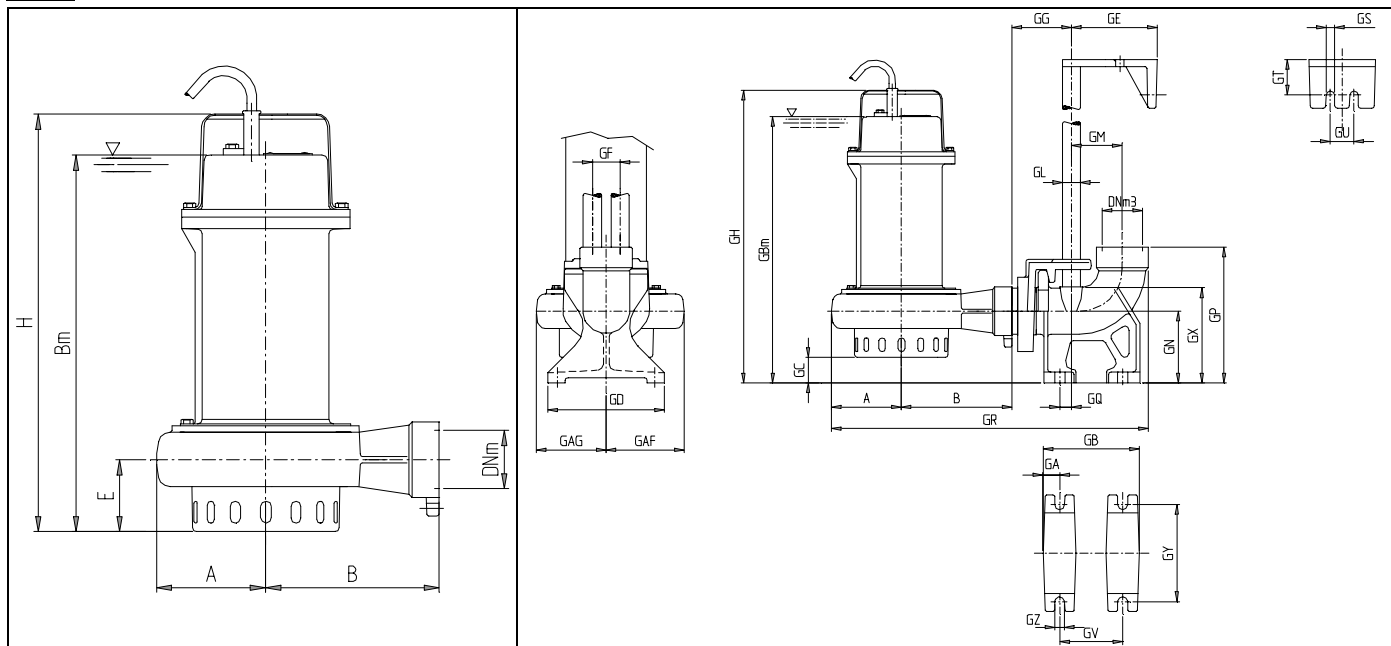

• These drawings do not represent actual product appearance. Refer to the outline on the previous page.

A	AE2	B	Bm	DA	DAF	DAG	DB	DBm	DC	DD	DE	DF	DG	DH	DL	DN	DNm
110	125	174	372	25	120	102	140	404	32	168	124	40	84	442	¾	104	2
DNm1	DNm3	DQ	DR	DS	DT	DU	DV	DX	DY	DZ	E	GA	GAF	GAG	GB	GBm	GC
50	2	38.5	449	12	51	34	91	183.5	140	14	72	25	120	102	140	404	32
GD	GE	GF	GG	GH	GL	GM	GN	GP	GQ	GR	GS	GT	GU	GV	GX	GY	GZ
168	124	40	84	442	¾	74	104	197	17	480	12	51	34	91	140	140	13
H	K2	W2															
410	165	18															

Dimensions 'mm' except than: DL-inches DNm-inches DNm3-inches GL-inches	Mass: 25 Kg	Possible installations:	I1-I2-I4
---	-------------	-------------------------	----------

\*For more information see the descriptive sections

